

# Improved Filter Selection Method for Filter Bank Common Spatial Pattern for EEG-based BCI Systems

Geun-Ho Park, Yu-Ri Lee, and Hyoung-Nam Kim

Pusan National University/Department of Electrical & Computer Engineering, Busan, Republic of Korea

Email: hnkim@pusan.ac.kr

**Abstract**— In this paper, we propose an improved filter selection method using Welch's  $t$ -test based on discriminative filter bank common spatial pattern (DFBCSP). Existing DFBCSP used the Fisher ratio in order to find out discriminative filters. However, the Fisher ratio can be used to know only comparative value of distinguishability but may not become a meaningful criterion to reject null hypothesis. As a reasonable alternative, we have introduced the Welch's  $t$ -test to find out not only contributory but also redundant filters used to classify features efficiently. Experimental results show that the classification accuracy increased by 1.28% on average when using the proposed filter selection method.

**Index Terms**— Brain-Computer Interface (BCI), Electroencephalography (EEG), Common Spatial Pattern (CSP), Discriminative Filter Bank Common Spatial Pattern (DFBCSP), Welch's  $t$ -test

## I. INTRODUCTION

<sup>1</sup> Brain-Computer Interface (BCI) is a direct communication system between a human brain and a computer without any conventional input devices. In order to obtain useful information from brain signals, most of BCI systems use scalp electroencephalography (EEG) because of its feasibility. EEG is the measurement of an electrical signal induced by neuron activity. Because EEG usually represents some patterns related to subject's intention, BCI utilizes these useful features including important information. Especially, motor imagery conducted by imagining hand or foot movement has been an important part of studies in BCI research [1]-

[3]. The performance of the BCI system mainly depends on the classification accuracy of motor imagery.

However, there are some difficulties in achieving high classification accuracy. First, EEG patterns are slightly different from each other. Personal EEG features show different patterns individually in frequency domain as well. This subject-specific difference may cause the performance degradation in non-adaptive BCI systems. Hence, BCI needs to acquire subject-specific frequency features. Second, EEG has extremely low spatial resolution [4] as compared with other neuroimaging technology, such as magnetic resonance imaging (MRI) and positron emission tomography (PET), because of the conductivity of scalp. At multi-channel environment, low spatial resolution makes it hard to analyze EEG patterns and to decide correct subject's intention. Therefore, it is essential to apply spatial filtering technique in order to solve this problem. Common spatial pattern (CSP) has been extensively investigated, especially in the field of constructing a spatial filter that maximizes the difference in variance of each motor task [5]-[8]. However, CSP has a shortcoming that the proper frequency band discriminating two tasks should be manually found through repeated experiments. To simplify this manual processing method, modified BCI systems were proposed by introducing sub-band common spatial pattern (SBCSP) [9], filter bank common spatial pattern (FBCSP) [10], and discriminative filter bank common spatial pattern (DFBCSP) [11].

The process of automatic frequency-band selection was proposed in DFBCSP, where more informative frequency bands were found in accordance with subjects by calculating the signal power and the Fisher ratio in each band. However, DFBCSP involved fixed number of filters, resulting in fixed feature dimensions. However, to enhance the classification accuracy in using DFBCSP, the number of filters is needed to be properly varied whenever subjects or EEG data are changed. To find the proper number of filters, additional analysis is required to investigate the classification accuracy according to the number of filters. This inconvenient process is not suitable for machine-learning based BCI systems. In this

---

Manuscript received November 25, 2013; revised January 10, 2014.

This work was supported by Basic Science Research Program through the National Research Foundation of Korea (NRF) funded by the Ministry of Education, Science and Technology (2012R1A1A2008555).

Corresponding author: Hyoung-Nam Kim (hnkim@pusan.ac.kr)

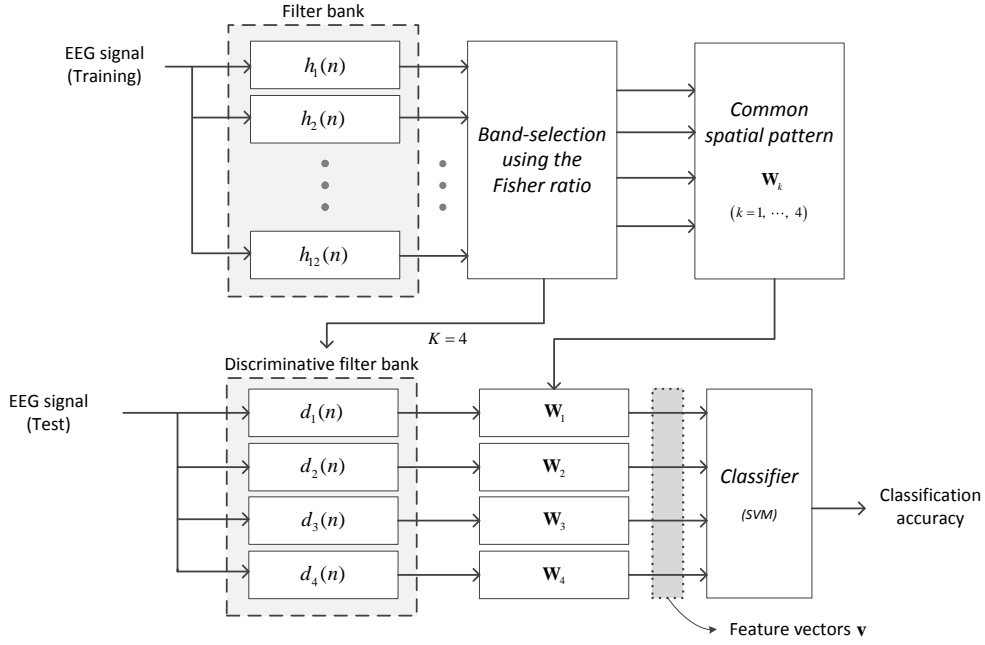

Figure 1. Block diagram of the discriminative filter bank common spatial pattern.

paper, to solve this problem, Welch's  $t$ -test [12] is introduced to automatically decide the proper number of filters. In addition, the proposed BCI system improves the classification accuracy by selecting suitable feature dimensions and removing redundant frequency bands.

This paper is organized as follows. Section II introduces the common spatial pattern (CSP) algorithm, the discriminative filter bank common spatial pattern (DFBCSP) and the proposed DFBCSP system including Welch's  $t$ -test. The simulation results are presented in Section III. Finally, conclusions are drawn in Section IV.

## II. METHODS

### A. Common Spatial Pattern (CSP) [5]

The Common spatial pattern (CSP) algorithm is effective in constructing an optimal spatial filter that discriminates two classes of EEG signals by diagonalizing two spatial covariance matrices simultaneously [5]. Each normalized spatial covariance matrix can be obtained by

$$\mathbf{C}_i = \frac{\mathbf{X}_i \mathbf{X}_i^T}{\text{trace}(\mathbf{X}_i \mathbf{X}_i^T)}, \quad (1)$$

where  $\mathbf{X}_i (N \times T)$  is an EEG signal matrix and  $i \in \{1, 2\}$  is the motor imagery task such as foot or hand movement.  $N$  is the number of channels and  $T$  is the length of EEG samples in time. For obtaining each group of EEG signal to be efficiently separated, the averaged spatial covariance matrix  $\bar{\mathbf{C}}_i$  is calculated by averaging each group of spatial covariance matrix. Using these averaged spatial covariance matrices, a composite spatial covariance matrix is obtained by

$$\mathbf{C}_c = \bar{\mathbf{C}}_1 + \bar{\mathbf{C}}_2. \quad (2)$$

The composite matrix  $\mathbf{C}_c$  is factored as  $\mathbf{C}_c = \mathbf{S}_c \mathbf{\Lambda}_c \mathbf{S}_c^T$  where  $\mathbf{S}_c$  is an eigenvector matrix and  $\mathbf{\Lambda}_c$  is a diagonal matrix of eigenvalues. Using a whitening transformation matrix  $\mathbf{A} = \sqrt{\mathbf{\Lambda}_c^{-1}} \mathbf{S}_c^T$ , each averaged spatial covariance matrix is transformed as

$$\mathbf{E}_1 = \mathbf{A} \bar{\mathbf{C}}_1 \mathbf{A}^T \text{ and } \mathbf{E}_2 = \mathbf{A} \bar{\mathbf{C}}_2 \mathbf{A}^T. \quad (3)$$

Because  $\mathbf{E}_1$  and  $\mathbf{E}_2$  have common eigenvectors,  $\mathbf{E}_1$  and  $\mathbf{E}_2$  are also factored as

$$\mathbf{E}_1 = \mathbf{M} \mathbf{\Lambda}_1 \mathbf{M}^T \text{ and } \mathbf{E}_2 = \mathbf{M} \mathbf{\Lambda}_2 \mathbf{M}^T \text{ and } \mathbf{\Lambda}_1 + \mathbf{\Lambda}_2 = \mathbf{I}, \quad (4)$$

where  $\mathbf{M}$  is an eigenvector matrix and  $\mathbf{\Lambda}_i$  is a diagonal matrix of eigenvalues. In (4), eigenvalues in  $\mathbf{\Lambda}_1$  are assumed to be sorted in descending order. Since the sum of two eigenvalue matrices is an identity matrix, the eigenvector corresponding to the largest eigenvalue in  $\mathbf{\Lambda}_1$  has the smallest eigenvalue in  $\mathbf{\Lambda}_2$  and vice versa. Using this property, the eigenvector matrix  $\mathbf{M}$  is useful for classifying each task. Some eigenvectors with large eigenvalues in  $\mathbf{\Lambda}_1$  or  $\mathbf{\Lambda}_2$  can be used for extracting feature vectors of test EEG signals. Since the most discriminative eigenvectors are the first and last columns of  $\mathbf{M} (N \times N)$ , submatrix  $\mathbf{M}' (N \times 2m)$  can be determined by extracting the first  $m$  columns and the last  $m$  columns of  $\mathbf{M}$ .

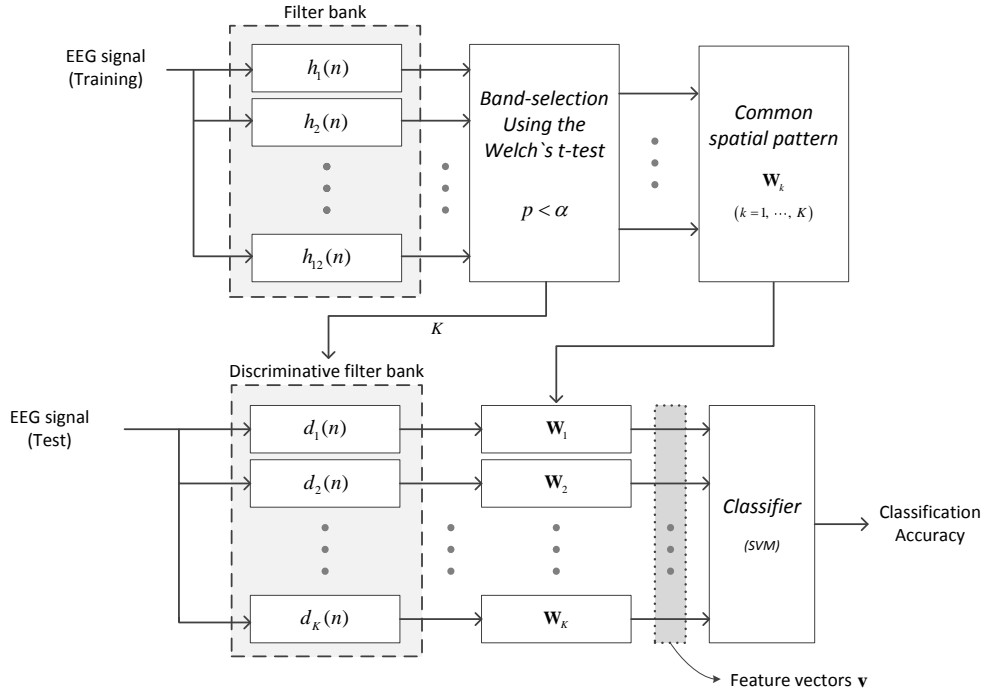

Figure 2. Block diagram of the proposed discriminative filter bank common spatial pattern.

Finally, the projection matrix  $\mathbf{W}$  is obtained by

$$\mathbf{W} = \mathbf{A}^T \mathbf{M}' \quad (5)$$

and the decomposition of a test EEG signal  $\mathbf{X}$  is calculated by

$$\mathbf{Z} = \mathbf{W}^T \mathbf{X}. \quad (6)$$

Since the  $\mathbf{X}$  is projected onto the spatial filter  $\mathbf{W}$ , the feature vectors used for classifying two tasks can be calculated by the  $p$ -th row vector  $\mathbf{z}_p$  ( $p=1, 2, \dots, 2m$ ) of signal  $\mathbf{Z}$ . The feature vector  $\mathbf{v} = [v_1, v_2, \dots, v_p, \dots, v_{2m}]^T$  can be obtained by

$$v_p = \log \left( \frac{\text{var}(\mathbf{z}_p)}{\sum_{j=1}^{2m} \text{var}(\mathbf{z}_j)} \right). \quad (7)$$

The projection matrix  $\mathbf{W}$  is also obtained by minimizing the Rayleigh quotient of the spatial covariance matrices to achieve high discriminability of EEG data  $\mathbf{X}_1$  and  $\mathbf{X}_2$  [13]. The projection matrix  $\mathbf{W}$  can be briefly estimated by

$$\mathbf{W} = \arg \max_{\mathbf{W}} \frac{\text{trace}(\mathbf{W}^T \bar{\mathbf{C}}_1 \mathbf{W})}{\text{trace}(\mathbf{W}^T \bar{\mathbf{C}}_2 \mathbf{W})}, \quad (8)$$

where  $\bar{\mathbf{C}}_i$  is the averaged covariance matrix of EEG data  $\mathbf{X}_i$ .

### B. Discriminative Filter Bank Common Spatial Pattern (DFBCSP) [11]

DFBCSP was proposed to find the subject-specific frequency band which discriminates one task from the other as in Fig. 1 [11]. To find discriminative frequency band adaptively, filter bank is introduced to CSP-based BCI system. Filter bank is made up of twelve band-pass filters covering 6-32Hz. Each filter  $h_j(n)$  ( $j=1, \dots, 12$ ) has 4Hz pass-band and is laid to overlap 2Hz with adjacent other filter's pass-band.

To find out subject-specific frequency bands, the average power of EEG signal,  $P_{i,j}$  can be obtained from

$$P_{i,j} = \frac{1}{T} \sum_{n=1}^T (x_{i,j}[n])^2 \quad (9)$$

where  $x_{i,j}$  is  $j$ th band-pass filtered EEG signal and  $T$  is the number of the samples. The Fisher ratio  $F_j$ , which means how much the tasks are well distinguished, can be obtained by

$$F_j = \frac{(\bar{X}_1 - \bar{X}_2)^2}{s_1^2 + s_2^2}, \quad (10)$$

where  $\bar{X}_i$  is the sample mean of  $P_{i,j}$  and  $s_i^2$  is the sample variance of  $P_{i,j}$ . Out of twelve filters,  $K$  filters ( $d_k(n)$ ,  $k=1, \dots, K$ ) which have the largest Fisher ratio are selected

to establish discriminative filters. In [11],  $K$  was determined to four as shown in Fig. 1.

### C. Welch's $t$ -test [12]

$T$ -test is used to verify a hypothesis if the test statistic of null hypothesis follows  $t$ -distribution. Especially, Welch's  $t$ -test is used to verify the null hypothesis which assumes that two populations have same sample mean [12]. The  $p$ -value is a probability of obtaining a test statistic on condition that null hypothesis is true. If the  $p$ -value is less than significance level, generally 0.05 or 0.01, null hypothesis is rejected.

### D. DFBCSP using the Welch's $t$ -test

DFBCSP used the Fisher ratio to find out some filters which contribute to the performance improvement. In this paper, we propose the Welch's  $t$ -test to find out whether a filter is contributory or unnecessary according to its  $p$ -value compared with the significance level which is used as a threshold for searching redundant filters. It is natural that the number of useful filters is changed whenever subject and training data are changed. Fig. 2 shows the block diagram involving the proposed frequency band selection method. Unlike the fixed number of filter banks in [7], the number of required filter banks,  $K$  in Fig. 2, varies with the band selection criterion based on the  $p$ -value of each filter and significance level  $\alpha$ . The number of discriminative filters  $K$  is an integer value in  $1 \leq K \leq 6$ . To calculate a  $p$ -value, test statistic as in (11) and degree of freedom as in (12) can be obtained by [12]

$$t = \frac{\bar{X}_1 - \bar{X}_2}{\sqrt{\frac{s_1^2}{T_1} + \frac{s_2^2}{T_2}}}, \quad (11)$$

$$\nu = \frac{\left(\frac{s_1^2}{T_1} + \frac{s_2^2}{T_2}\right)^2}{\left(\frac{s_1^4}{T_1^2} \nu_1\right) + \left(\frac{s_2^4}{T_2^2} \nu_2\right)}, \quad (12)$$

where  $\bar{X}_i$  is sample mean,  $s_i^2$  is sample variance,  $T_i$  is the number of samples and  $\nu_i = T_i - 1$ .  $T$ -distribution varies according to degree of freedom which can be obtained from (12).

## III. SIMULATION RESULTS

BCI competition III data set IVa [5] was used to verify the performance of the proposed method. EEG signal was measured from five subjects named 'aa', 'al', 'av', 'aw', and 'ay'. Each subject was indicated to conduct right hand and foot imagery when the cue appeared on the monitor screen and 280 trials were performed for each subject. EEG data were extracted from 7 electrodes near the

TABLE I. PERFORMANCE COMPARISON WITH DFBCSP AND THE PROPOSED DFBCSP (MEAN  $\pm$  STANDARD DEVIATION)

Subject	Classification Accuracy (%)			
	DFBCSP	Number of Filter banks $K$	The proposed DFBCSP	Number of Filter banks $K$
aa	82.43 $\pm$ 6.90	4	83.50 $\pm$ 6.58	2.34 $\pm$ 0.90
al	91.75 $\pm$ 5.55	4	92.61 $\pm$ 5.13	5.06 $\pm$ 0.53
av	56.86 $\pm$ 8.81	4	58.75 $\pm$ 8.85	3.18 $\pm$ 0.67
aw	82.98 $\pm$ 6.77	4	84.37 $\pm$ 6.28	3.2 $\pm$ 1.5
ay	90.61 $\pm$ 5.17	4	91.79 $\pm$ 4.91	4.6 $\pm$ 1.46

sensorimotor area, i.e., F3, F4, C3, Cz, C4, P3 and P4. Support Vector Machine (SVM) [14] was used to classify the feature vector. In order to precisely estimate the performance of the BCI system with the fixed number of filters (conventional) and the variable number of filters (proposed), 10  $\times$  10-fold cross-validation was used [11].

The resulting classification accuracy and the number of filters used to classify feature vectors are in Table I. For all of subjects, classification accuracy was increased. For 'al' and 'ay', the numbers of filters increased as 5.06 and 4.6, respectively. However, for 'aa', 'av' and 'aw', the number of filters decreased as 2.34, 3.18 and 3.2, respectively. These results show that the proposed DFBCSP selects proper filters and these filters discriminate two tasks more efficiently.

## IV. CONCLUSION

In this paper, Welch's  $t$ -test was employed to DFBCSP instead of the Fisher ratio for determining the number of filters. As a result, the classification accuracy increased by 1.28% on average. The proposed DFBCSP improved the performance of the EEG-based BCI system by removing unnecessary filters which have a larger  $p$ -value than the significance level. Consequently, the results of this study confirm that the proposed DFBCSP contributes to finding out proper feature dimensions and discriminative frequency features, resulting in classifying tasks more correctly.

## ACKNOWLEDGMENT

This research was supported by Basic Science Research Program through the National Research Foundation of Korea (NRF) funded by the Ministry of Education, Science and Technology (2012R1A1A2008555).

## REFERENCES

- [1] J. R. Wolpaw, "Brain-computer interfaces as new brain output path-ways," *J. Physiol.*, vol. 579, pp. 613-619, Mar. 2007.

- [2] A. Akrami, S. Solhjoo, A. Motie-Nasrabadi, and M. Hashemi-Gol-payegani, "EEG-based mental task classification: Linear and nonlinear classification of movement imagery," in *Proc. 27<sup>th</sup> IEEE Eng. Med. Biol. Conf.*, Sep. 2005, pp. 4626-4629.
- [3] H. Ramoser, J. Müller-Gerking, and G. Pfurtscheller. "Optimal Filtering of Single Trial EEG During Imagined Hand Movement," *IEEE Trans. Rehab. Eng.*, vol. 8, no. 4, pp.441-446, Dec. 2000.
- [4] R. Srinivasan, "Methods to Improve the Spatial Resolution of EEG," *International Journal of Bioelectromagnetism.*, vol. 1, no. 1, pp. 102-111, 1999.
- [5] H. Ramoser, J. Müller-Gerking, and G. Pfurtscheller. "Optimal Filtering of Single Trial EEG During Imagined Hand Movement," *IEEE Trans. Rehab. Eng.*, vol. 8, no. 4, pp.441-446, Dec. 2000.
- [6] Z. J. Koles, J. C. Lind, and A. C. K. Soong, "Spatio-temporal decomposition of the EEG: A general approach to the isolation and localization of sources," *Electroencephalogr. Clin. Neurophysiol.*, vol. 95, pp. 219-230, Oct. 1995.
- [7] H. Wang, Q. Tang and W. Zheng, "L1-Norm-Based Common Spatial Patters," *IEEE Trans. Biomed. Eng.*, vol. 59, no. 3, pp.653-662, Mar. 2012.
- [8] M. Arvaneh, C. Guan, K. K. Ang, C. Quek, "Optimizing Spatial Filters by Minimizing Within-Class Dissimilarities in Electroencephalogram-Based Brain-Computer Interface," *IEEE Trans. Networks and Learning sys*, vol. 24, no. 4, pp.610-619, April. 2013.
- [9] Q. Novi, C. Guan, T. H. Dat, and P. Xue, "Sub-band common spatial pattern for brain-computer interface," in *Proc. 3<sup>rd</sup> Int. Conf. Neural Eng. IEEE Eng. Med. Biol. Soc. (EMBS)*, May 2007, pp. 204-207.
- [10] K. K. Ang, Z. Y. Chin, H. Zhang, and C. Guan, "Filter bank common spatial pattern (FBCSP) in brain-computer interface," in *Proc. IEEE Int. Joint Conf. Neural Netw.*, Jun. 2008, pp. 2390-2397.
- [11] K. Thomas, C. Guan, C. Lau, A. Vinod and K. Ang, "A new discriminative common spatial pattern method for motor imagery brain-computer interfaces," *IEEE Trans. Biomed. Eng.*, vol. 56, no. 11, pp. 2730-2733, Nov. 2009.
- [12] Welch. B. L, "The generalization of "Student's" problem when several different population variances are involved". *Biometrika*, vol. 34, no. 1-2, pp. 28-35, Feb. 1947.
- [13] S. Sanei, *Adaptive Processing of Brain Signals*, 1<sup>st</sup> ed. University of Surrey, U.K.: Wiley, 2013, ch. 6, pp. 112-115.
- [14] F. Lotte, M. Congedo, A. Lécuyer, F. Lamarche and B. Arnaldi, "A review of classification algorithms for EEG-based Brain-computer Interfaces," *Journal of Neural Eng.*, vol. 4, no. 2, Jun. 2007.

**Geun-Ho Park** received the B.S. degrees in electronic and electrical engineering from Pusan National University (PNU), Busan, Korea, in 2013. He is currently working toward the M.S. degree at the Communications and Signal Processing Laboratory (CSPL), Department of Electronics Engineering at Pusan National University (PNU), Busan, Korea. His main research interests are in the area of digital signal processing, machine-learning, in particular, bio signal processing for Brain-computer Interface (BCI).



**Yu-Ri Lee** received the B.S. and M.S. degree in electronic and electrical engineering from Pusan National University, Busan, Korea, in 2010 and 2012, respectively. She is currently working toward the Ph.D. degree at the Communications and Signal Processing Laboratory (CSPL), Department of Electrical & Computer Engineering at Pusan National University, Busan, Korea. Her main research interests are in the area of digital signal processing, bio signal processing, signal processing for digital broadcasting, and SCA.



**Hyoung-Nam Kim** (M'00) received the BS, MS, and PhD degrees in electronic and electrical engineering from Pohang University of Science and Technology (POSTECH), Pohang, Korea, in 1993, 1995, and 2000, respectively. From May 2000 to February 2003, he was with Electronics and Telecommunications Research Institute (ETRI), Daejeon, Korea, developing advanced transmission and reception technology for terrestrial digital television. In 2003, he joined the faculty of the Department of Electronics and Electrical Engineering at Pusan National University (PNU), Busan, Korea, where he is currently a professor. From February 2009 to February 2010, he was with the Department of Biomedical Engineering, Johns Hopkins University School of Medicine, as a Visiting Scholar. His research interests are in the area of digital signal processing, adaptive IIR filtering, bio signal processing, and RADAR/SONAR signal processing, in particular, signal processing for digital broadcasting, digital communications, and multimedia systems. Dr. Kim is a member of IEEE, IEICE, IEEK, and KICS.

